

## ALKALINE-MANGANESE DIOXIDE BATTERY

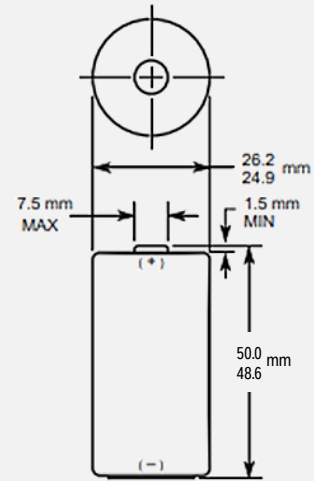

Size: C (LR14) PX1400



Dimensions shown are IEC standards

### KEY FEATURES

- Reliable Performance
- Excellent resistance to corrosion
- Designed to meet all major quality, safety and environmental standards:
  - Safety: IEC 60086-5
  - ANSI C 18.1M, Part-2
  - EU Battery Directive
  - Quality: ISO 14001 and 9001, Duracell World Class Continuous Improvement Program

### TYPICAL APPLICATIONS

- Sanitizer Dispensers
- Air Fresheners
- Paper Towel Dispensers
- Flashlights
- Soap Dispensers

### ELECTRICAL CHARACTERISTICS

- |   |           |
|---|-----------|
| ▪ Nominal capacity (25 mA Cont., .8V cut-off) | 8,240 mAh |
| ▪ Typical Voltage (at + 20 °C)                | 1.5 V     |
| ▪ AC Impedance @ 1kHz                         | 74 mΩ     |

### PHYSICAL CHARACTERISTICS

- |                  |   |
|------------------|---|
| ▪ Typical weight | 65.0 g (2.5 oz)                             |
| ▪ Typical volume | 26.9 cm <sup>3</sup> (1.6 in <sup>3</sup> ) |
| ▪ Terminals      | Flat  |

### OPERATING & STORAGE CONDITIONS

- |  |                                  |
|--|----------------------------------|
| ▪ Operating temperature range  | -20°C to 54°C<br>(-4°F to 130°F) |
| ▪ Recommended Storage (storage area should be clean, cool, dry and ventilated) | 5°C to 30°C<br>(41°F to 86°F)    |

TYPICAL PERFORMANCE

**Constant Current**

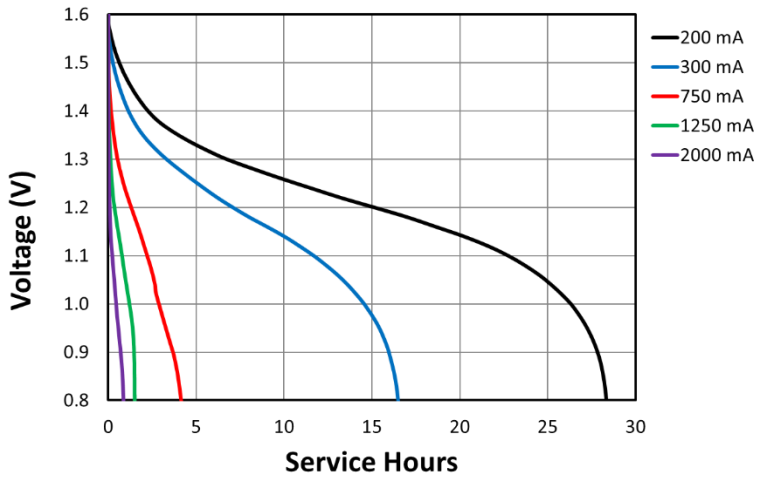

**Constant Resistance**

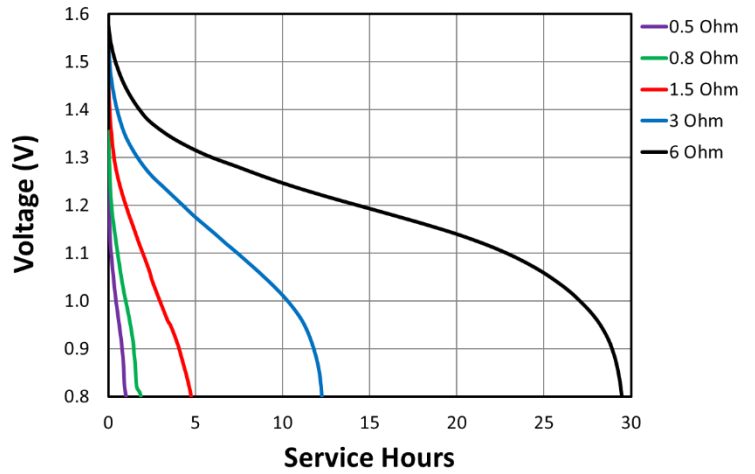

**Constant Power**

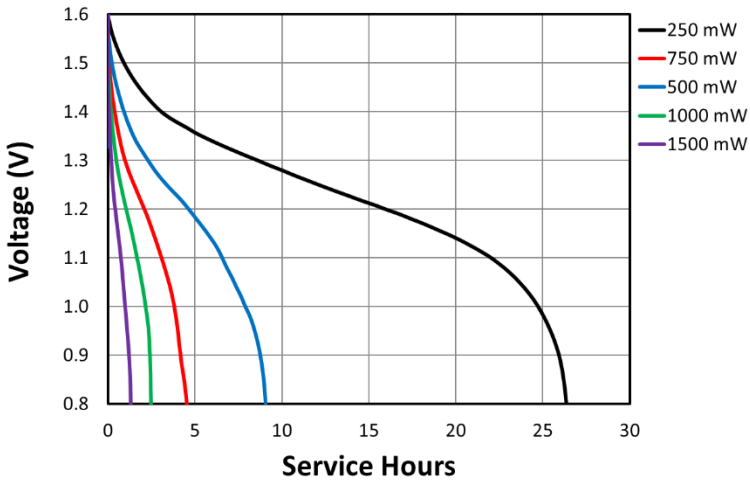

**Constant Current - 200 mA**

