

## PUC 2530 Pole Connect-it 300 cm black

The PUC 2530 is a 300 cm pole and is a part of the modular Connect-it system with which you can create a ceiling solution for medium- to large-sized displays.

<b>Garantie</b>	5 Jahre
<b>Max. Gewicht (kg)</b>	80

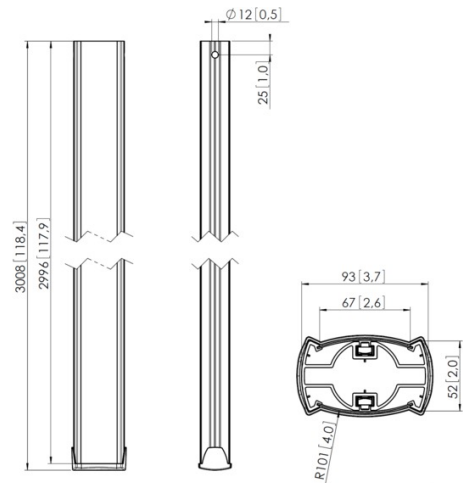

## PUC 2530 Pole Connect-it 300 cm black

The PUC 2530 is equipped with a multiple CIS® cable inlay system with which you can quickly and simply ensure that all cables are hidden. The pole is made of aluminium and, therefore, it can be easily cut at the required length. The Connect-it poles can be customized by the user. By inserting the plastic cover strips into the Connect-it pole or by replacing them by differently coloured strips, it can be customized to the house style of the customer. Multiple displays can easily be installed back-to-back, on top of each other or next to each other. Combine this pole with one of the Connect-it ceiling plates, Connect-it interface bar and Connect-it interface display strips for a complete ceiling solution.

## Merkmale

- Cable management
- Aluminium, easy to cut to length
- Befestigen mehrerer Displays

## Logistische Informationen

<b>EAN-Code Produkt</b>	8712285329388
<b>Nettogewicht (kg)</b>	6.8
<b>Single Box Width (mm)</b>	133
<b>Single Box Length (mm)</b>	3120
<b>Single Box Height (mm)</b>	81